

Liquid Architecture

Microarchitecture Optimization for Embedded Systems

D. Schuehler, B. Brodie, R. Chamberlain, R. Cytron,
S. Friedman, J. Fritts, P. Jones, P. Krishnamurthy,
J. Lockwood, S. Padmanabhan, and H. Zhang

Dept. of Computer Science and Engineering
Washington University in St. Louis
Supported by NSF ITR-0313203

Liquid Architecture

- Configurable architecture that can adapt to needs of particular application
- E.g., within an FPGA
 - Soft-core processors
- E.g., as an embedded processor
 - Tensilica supports configuration at fab time
 - Stretch support configuration at run time
- Today's discussion is on performance analysis and configuration choice

Block Diagram

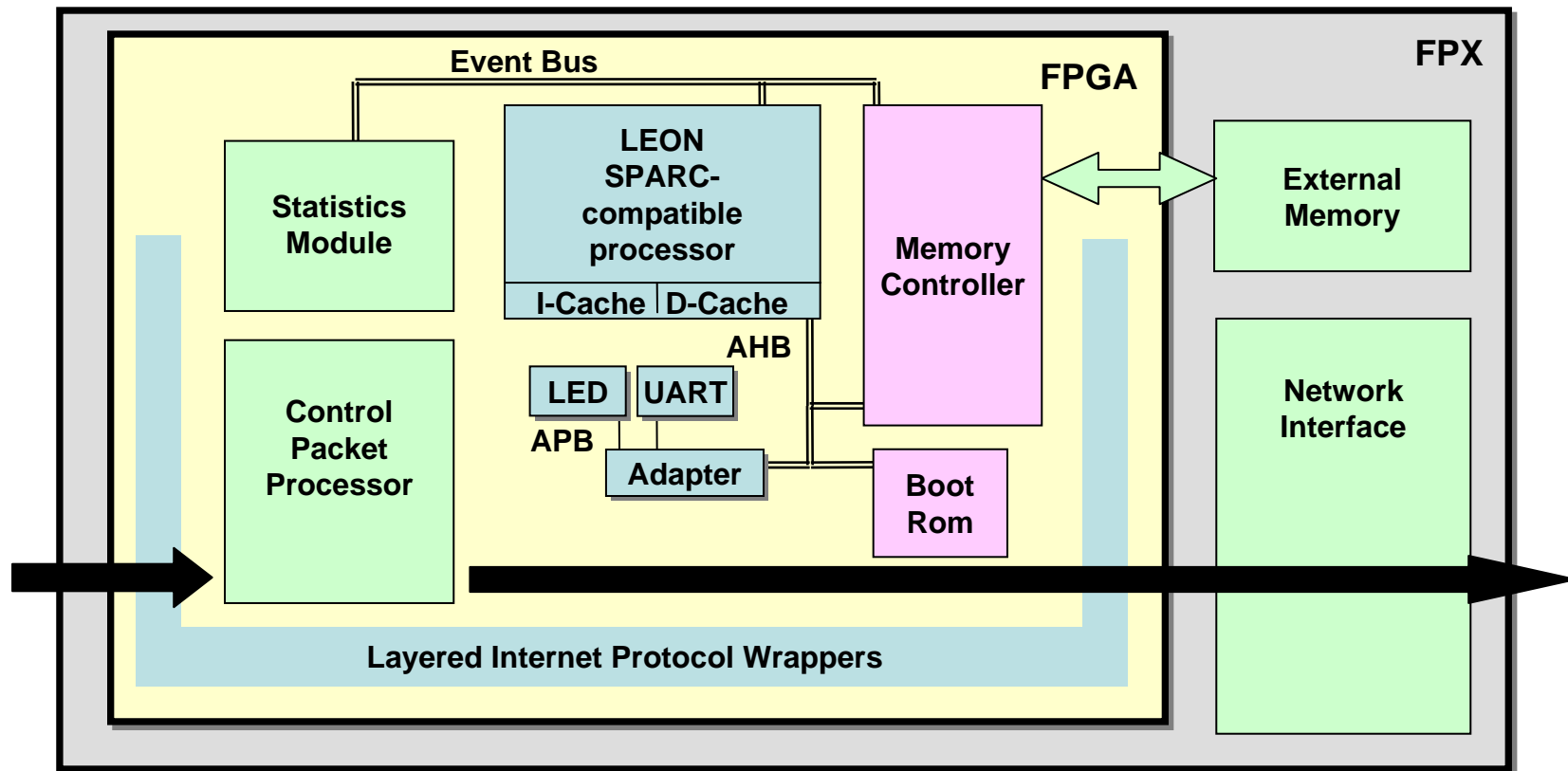

Microarchitecture Configurability

- Instruction set
- Memory subsystem
 - Cache size (I and D)
 - Associativity
 - Cache line size
- Co-processor(s)
- Instruction pipeline
- Full HDL source is available

Design Flow

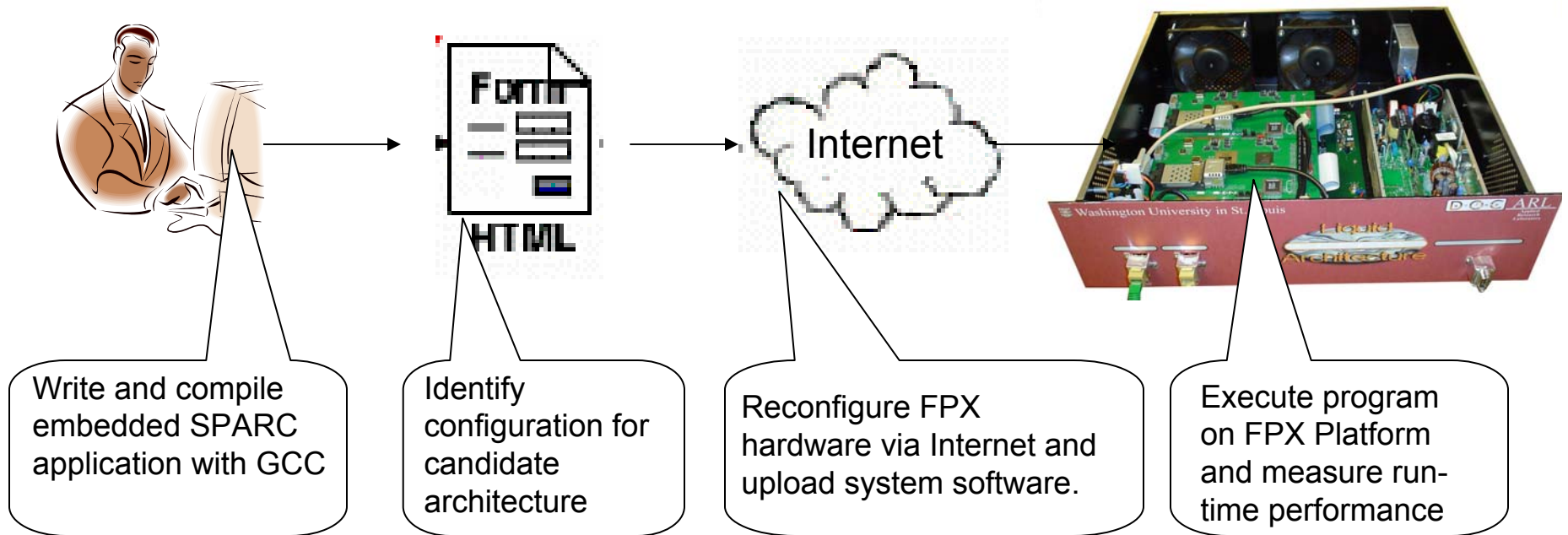

Cycle-accurate profiling

Method	Time / Cycles
.text	<input type="checkbox"/>
main	<input type="checkbox"/>
addQuery	<input checked="" type="checkbox"/>
findMatch	<input type="checkbox"/>
computeKey	<input type="checkbox"/>
computeBase	<input type="checkbox"/>
computeStep	<input checked="" type="checkbox"/>
fillQuery	<input type="checkbox"/>
Rnd	<input type="checkbox"/>

- Choose methods to profile from the user interface

Method	Address Range
.text	
main	
addQuery	<div style="text-align: center;"> Lo 0x4000027C 0x400003EF Hi </div>
findMatch	
computeKey	
computeBase	
computeStep	
fillQuery	
Rnd	

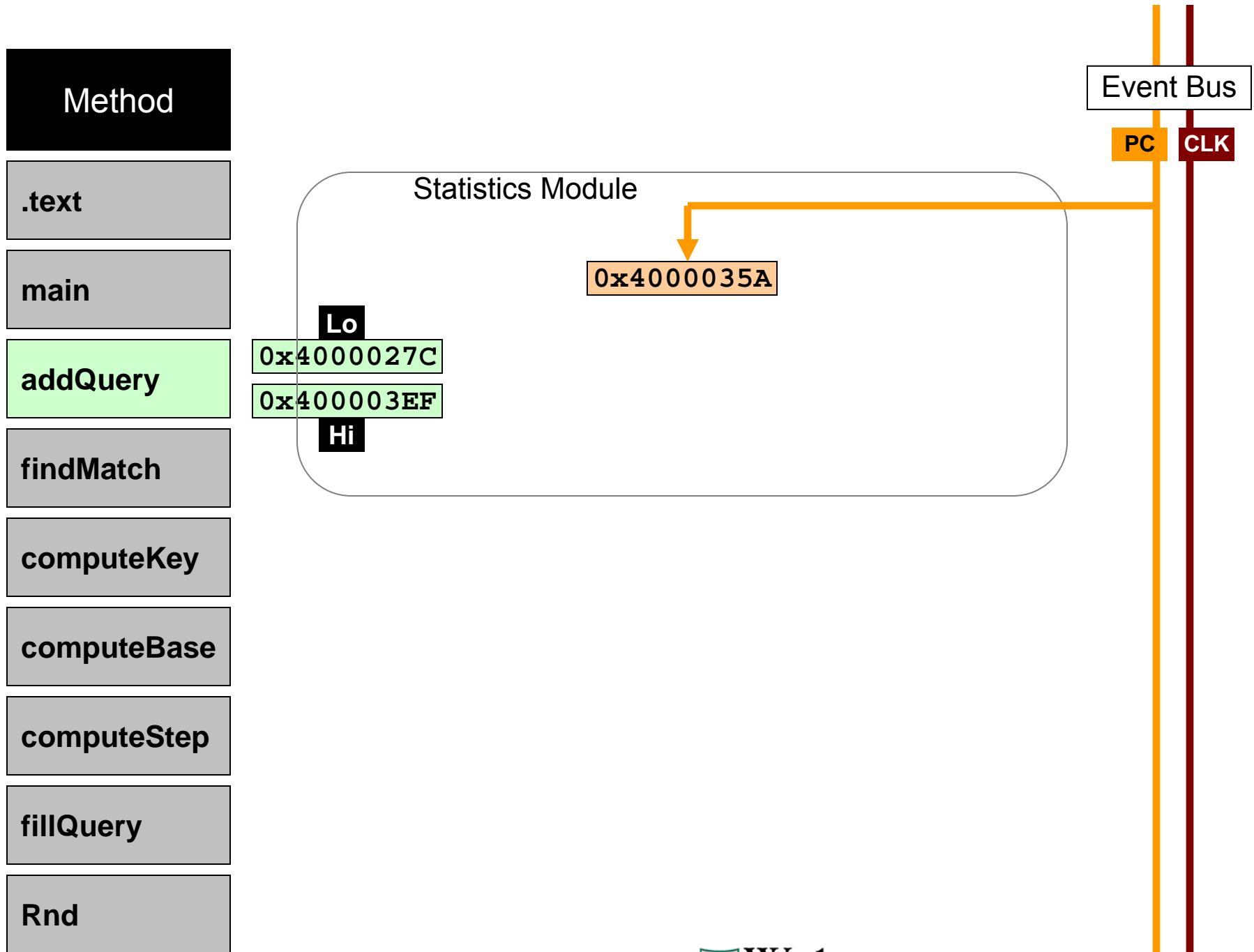

Function

.text

main

addQuery

findMatch

computeKey

computeBase

computeStep

fillQuery

Rnd

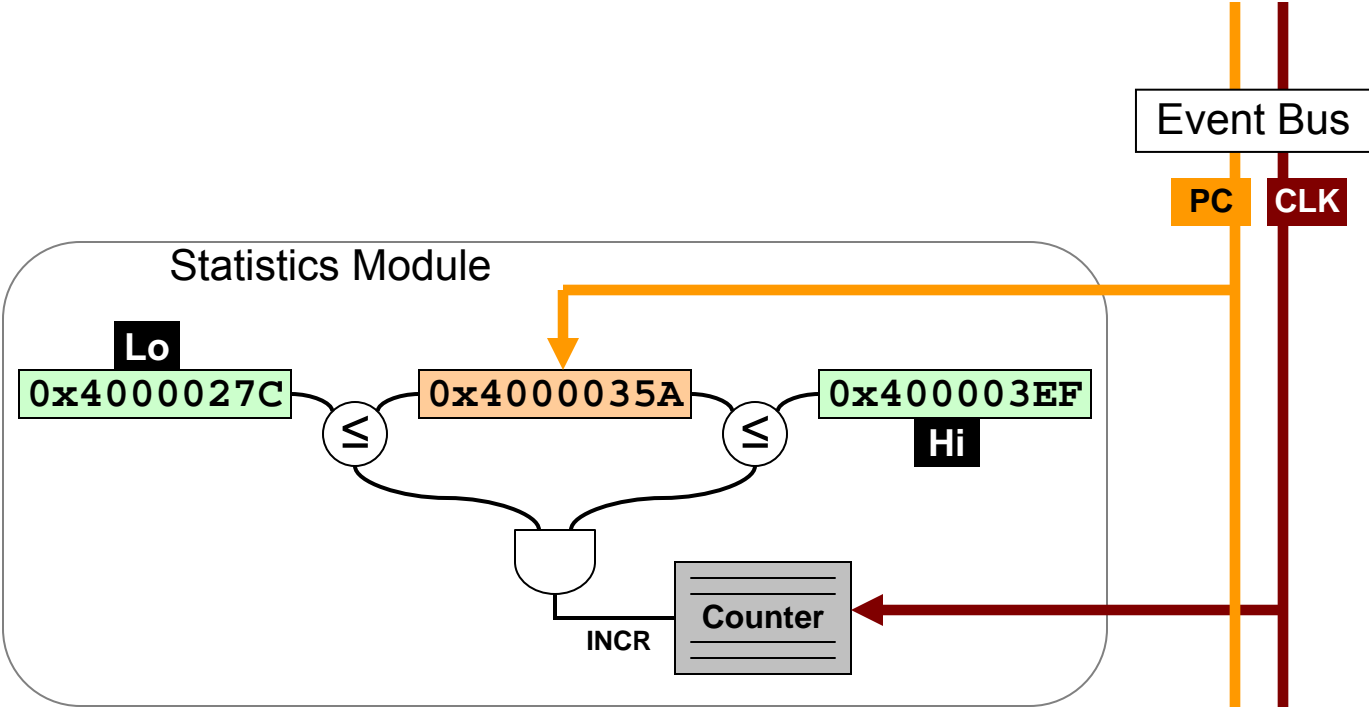

Function

- .text
- main
- addQuery
- findMatch
- computeKey
- computeBase
- computeStep
- fillQuery
- Rnd

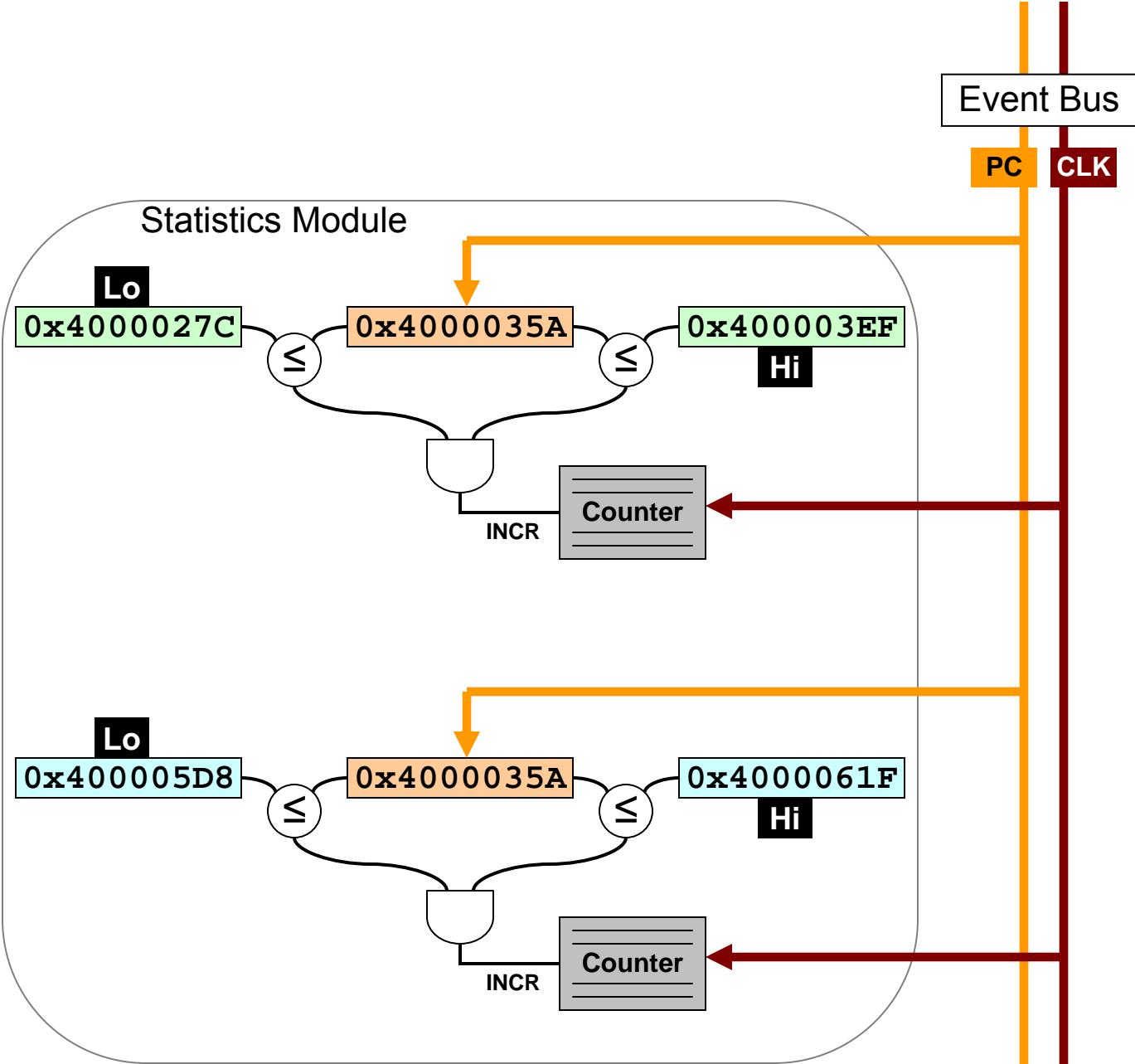

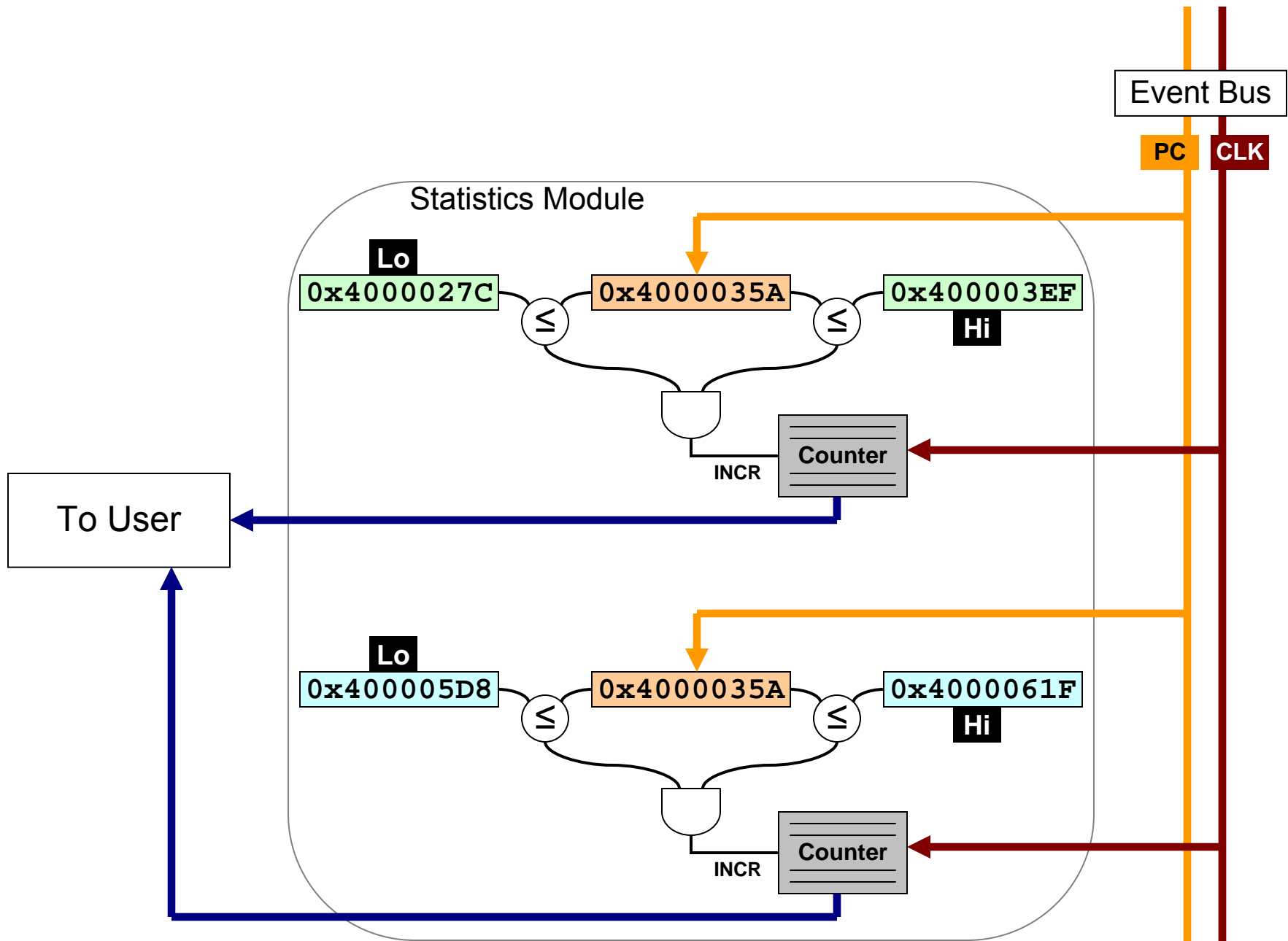

Where is time spent?

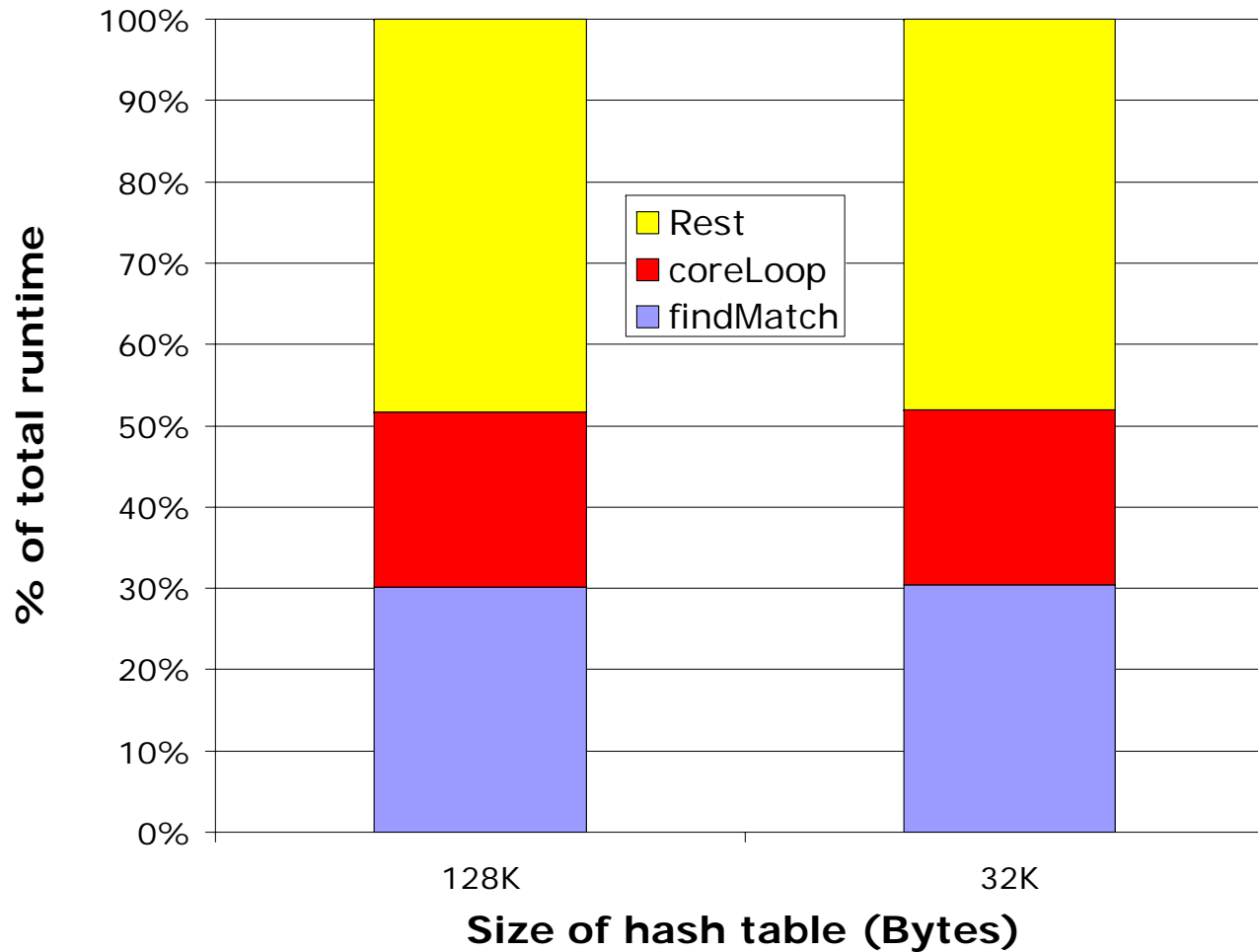

BLASTN
biosequence
search
application

Function	Time / Cycles	Cache Hits / Misses	
		Read	Write
.text	<input type="checkbox"/>	<input type="checkbox"/>	<input type="checkbox"/>
main	<input type="checkbox"/>	<input type="checkbox"/>	<input type="checkbox"/>
addQuery	<input checked="" type="checkbox"/>	<input checked="" type="checkbox"/>	<input checked="" type="checkbox"/>
findMatch	<input type="checkbox"/>	<input checked="" type="checkbox"/>	<input checked="" type="checkbox"/>
computeKey	<input type="checkbox"/>	<input type="checkbox"/>	<input type="checkbox"/>
computeBase	<input type="checkbox"/>	<input type="checkbox"/>	<input type="checkbox"/>
computeStep	<input checked="" type="checkbox"/>	<input checked="" type="checkbox"/>	<input checked="" type="checkbox"/>
fillQuery	<input type="checkbox"/>	<input type="checkbox"/>	<input type="checkbox"/>
Rnd	<input type="checkbox"/>	<input type="checkbox"/>	<input type="checkbox"/>

Expand to
measure cache
hits/misses

Measure Several Configurations

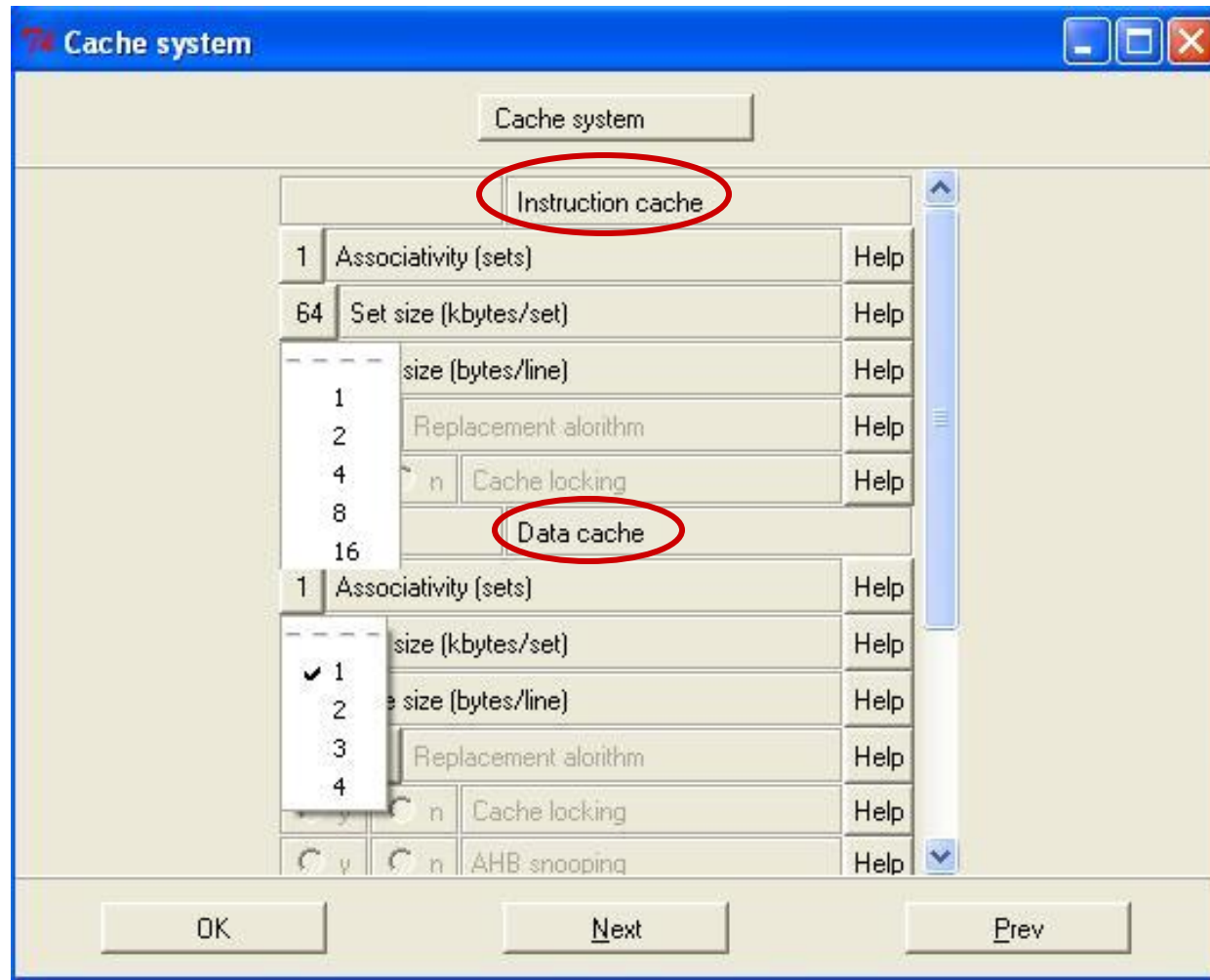

Impact of D-cache Configuration

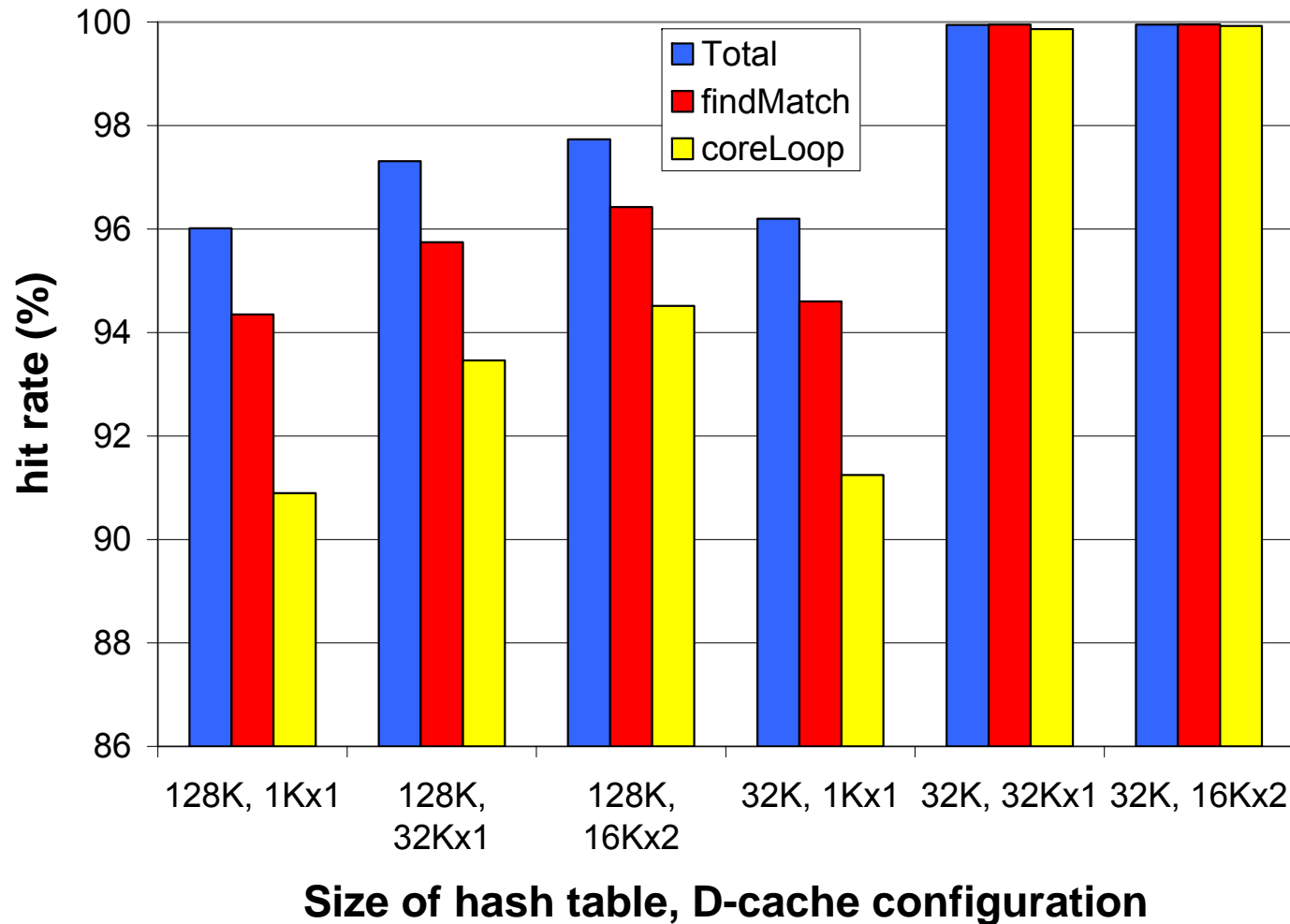

BLASTN
biosequence
search
application

Impact of I-cache Configuration

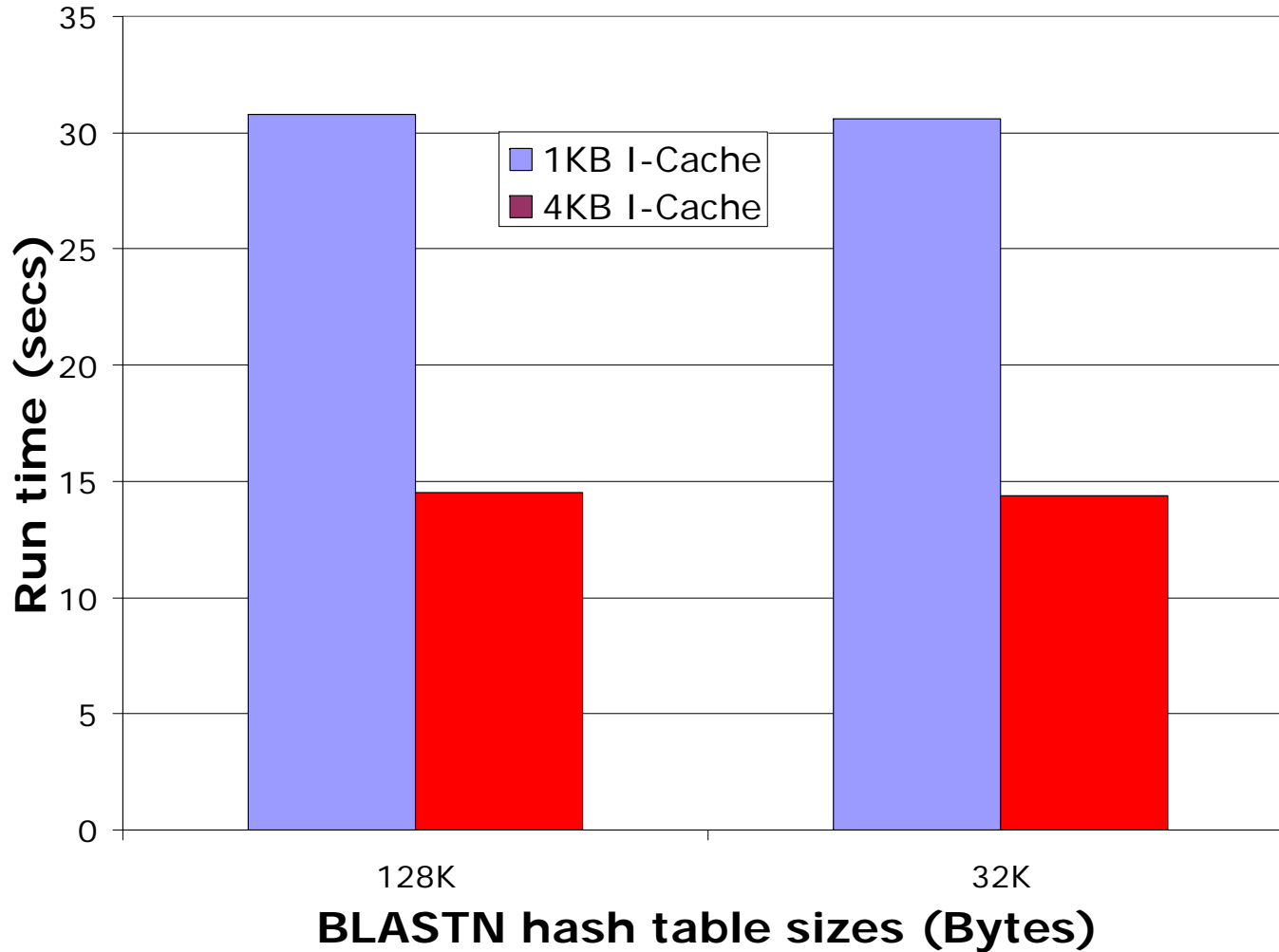

BLASTN
biosequence
search
application

Function	Time / Cycles	Cache Hits / Misses		Pipeline Stalls	Branch Predict
		Read	Write		
.text	<input type="checkbox"/>	<input type="checkbox"/>	<input type="checkbox"/>	<input type="checkbox"/>	<input type="checkbox"/>
main	<input type="checkbox"/>	<input type="checkbox"/>	<input type="checkbox"/>	<input type="checkbox"/>	<input type="checkbox"/>
addQuery	<input checked="" type="checkbox"/>	<input checked="" type="checkbox"/>	<input checked="" type="checkbox"/>	<input type="checkbox"/>	<input type="checkbox"/>
findMatch	<input type="checkbox"/>	<input checked="" type="checkbox"/>	<input checked="" type="checkbox"/>	<input type="checkbox"/>	<input type="checkbox"/>
computeKey	<input type="checkbox"/>	<input type="checkbox"/>	<input type="checkbox"/>	<input type="checkbox"/>	<input type="checkbox"/>
computeBase	<input type="checkbox"/>	<input type="checkbox"/>	<input type="checkbox"/>	<input type="checkbox"/>	<input type="checkbox"/>
computeStep	<input checked="" type="checkbox"/>	<input checked="" type="checkbox"/>	<input checked="" type="checkbox"/>	<input checked="" type="checkbox"/>	<input checked="" type="checkbox"/>
fillQuery	<input type="checkbox"/>	<input type="checkbox"/>	<input type="checkbox"/>	<input type="checkbox"/>	<input type="checkbox"/>
Rnd	<input type="checkbox"/>	<input type="checkbox"/>	<input type="checkbox"/>	<input type="checkbox"/>	<input type="checkbox"/>

Time for Single Run

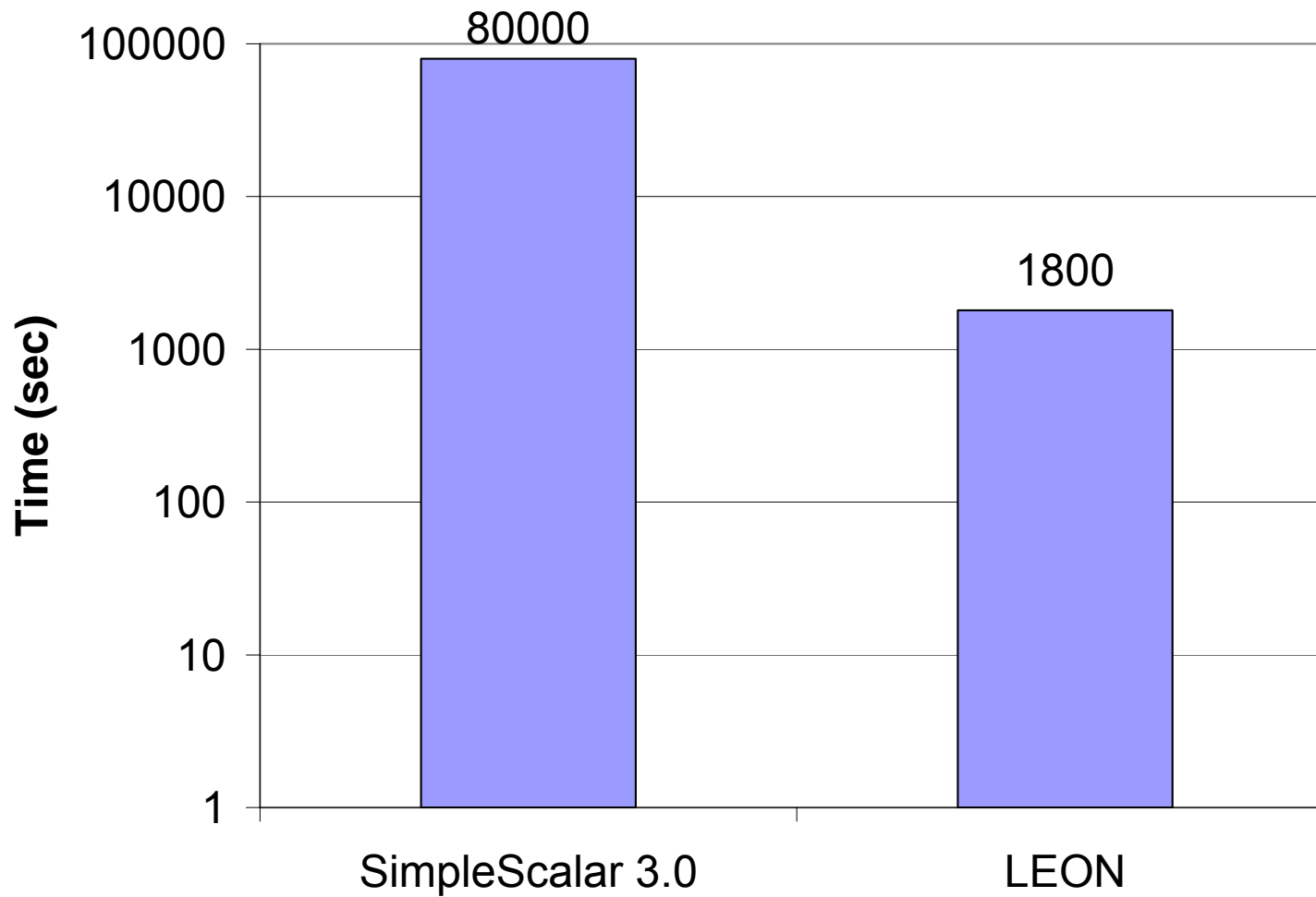

Almost 2 orders of magnitude faster than simulation

Implications of Slow Simulation

- Focus has historically been on measuring the performance of a single thread of a single application
- Real apps are often executed in a multitasking environment
 - Impacts cache behavior
 - Ignores OS (system call) performance
- Liquid architecture system enables direct measurement, including OS

OS Boot Sequence

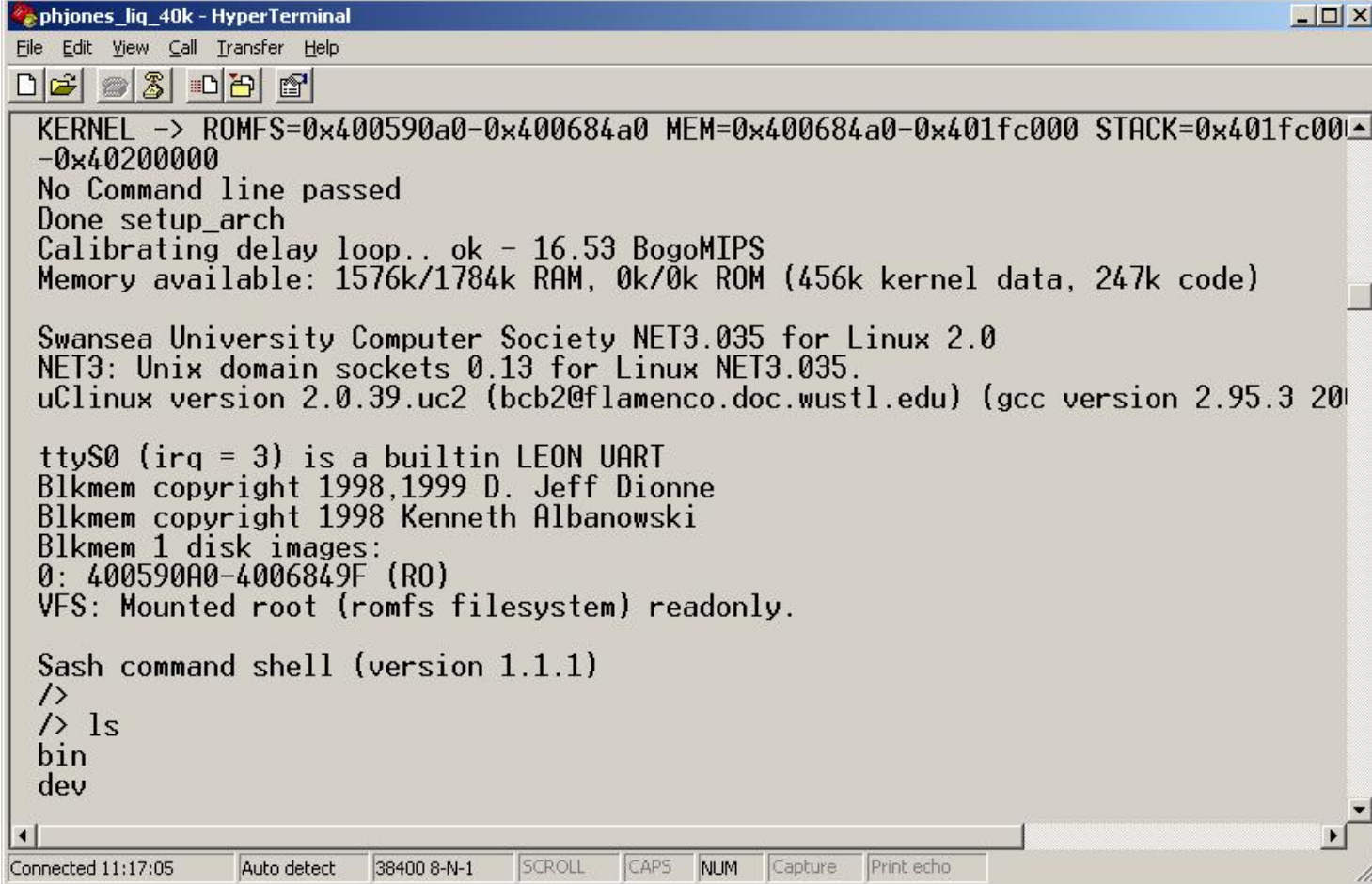

```
phjones_liq_40k - HyperTerminal
File Edit View Call Transfer Help
[Icons]
KERNEL -> ROMFS=0x400590a0-0x400684a0 MEM=0x400684a0-0x401fc000 STACK=0x401fc000
-0x40200000
No Command line passed
Done setup_arch
Calibrating delay loop.. ok - 16.53 BogoMIPS
Memory available: 1576k/1784k RAM, 0k/0k ROM (456k kernel data, 247k code)

Swansea University Computer Society NET3.035 for Linux 2.0
NET3: Unix domain sockets 0.13 for Linux NET3.035.
uClinux version 2.0.39.uc2 (bcb2@flamenco.doc.wustl.edu) (gcc version 2.95.3 20030804)

ttyS0 (irq = 3) is a builtin LEON UART
Blkmem copyright 1998,1999 D. Jeff Dionne
Blkmem copyright 1998 Kenneth Albanowski
Blkmem 1 disk images:
0: 400590A0-4006849F (RO)
VFS: Mounted root (romfs filesystem) readonly.

Sash command shell (version 1.1.1)
/>
/> ls
bin
dev

Connected 11:17:05  Auto detect  38400 8-N-1  SCROLL  CAPS  NUM  Capture  Print echo
```

Summary

- Run-time reconfigurable processors will be available sooner rather than later
- Determining desired configuration is a difficult design task
 - Large search space
 - Depends on accurate performance data
- Liquid architecture system enables direct measurement of performance properties

Current and Future Work

- Evaluation of several arch. design ideas
- Automated search of the design space
- Characterizing performance analysis methods
 - Analytic models
 - Simulation models
 - Direct execution models
- Usable as is for evaluating soft-core procs
- Like to extend to higher-speed procs