

*Review of:*  
**Specialized Hardware for Deep Network Packet  
Filtering**

- Paper by:
  - Young H Cho, Shiva Navab, William H Mangione-Smith (UCLA)
- Published in:
  - FPL 2002
- Review by:
  - Sarang Dharmapurikar

## Introduction

- String matching essential for deep packet inspection
- Becomes computationally intensive as the strings to be detected grow in number
- Parallel architectures required
- FPGAs suitable for implementation due to the re-programmability

## Related work

- SNORT
  - Packet sniffing and intrusion detection
- Hogwash
  - Wrapper around SNORT
  - Intrusion prevention by active modification of packets
- FPX
  - Cited for the wrappers !
- Brad Hutchings
  - Automaton using JHDL
- Prasanna and Sidhu
  - Automaton (NFA)
- PMC Sierra chipset
  - For packet classification

## Their approach

- Instantiate Hogwash rules in hardware and do a parallel comparison
- The packets which match one of the header rules are pulled apart and sent for payload inspection
- A naïve string matching for payload inspection
- Something like our CAMs! ;)

## This is their approach

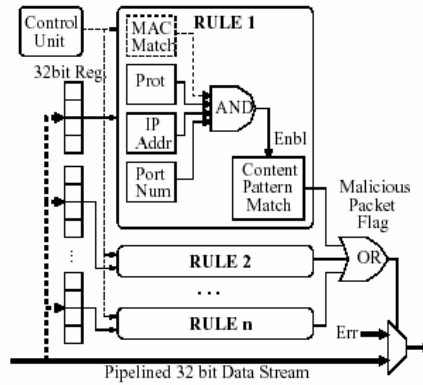

## How they do string matching

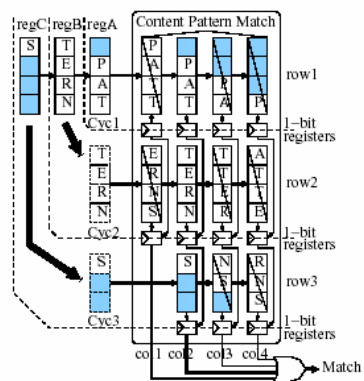

## Issues

- Non-scalable
  - Only 107 rules
- Better approaches exist
  - Mentioned but not compared
  - Project first and survey later?

## Conclusions

- Minimal contribution
  - Lacked new ideas for networking
  - Lacked new ideas for Reconfigurable logic
- Suitable as a class project but not as a conference paper
  - Not feasible for deep packet inspection or NIDS
- Good references though