

Computer Systems Architecture II

Chip-Multiprocessors: Applications and Architectures

CSE 561M

Prof. Patrick Crowley

Plan for Today

- Introduction
- Course Goals, Topics and Structure
- Preliminaries
- The next several weeks
- Assignment

Why does this course exist?

- Trend 1: Nearly all computers in the future will feature multicore processors
 - General purpose processors (i.e., x86) may see an annual doubling of on-chip core counts over the next ten years
 - Why?
 - Moore's Law
 - Diminishing returns from superscalar-based ILP
 - Clock rates no longer increasingly aggressively, due to power constraints
- Trend 2: Processor chips of all types are increasingly *integrated*
 - Found on the die: processor cores, controllers, accelerators, ...
- This course gives you an opportunity to study these trends and solve a concrete problem with a highly integrated multicore processor

Example: TI OMAP3430

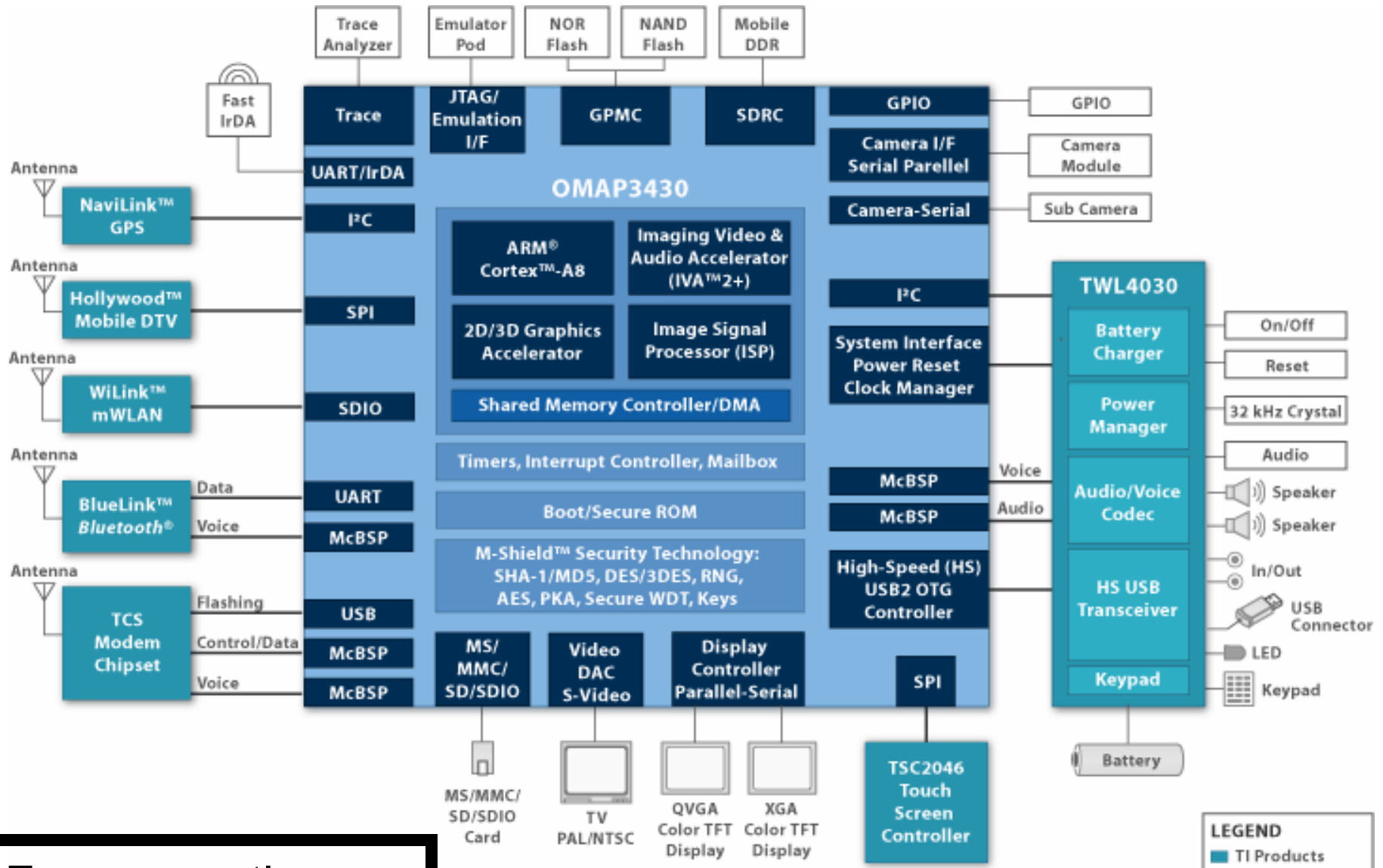

From www.ti.com

Example: IXP 2850

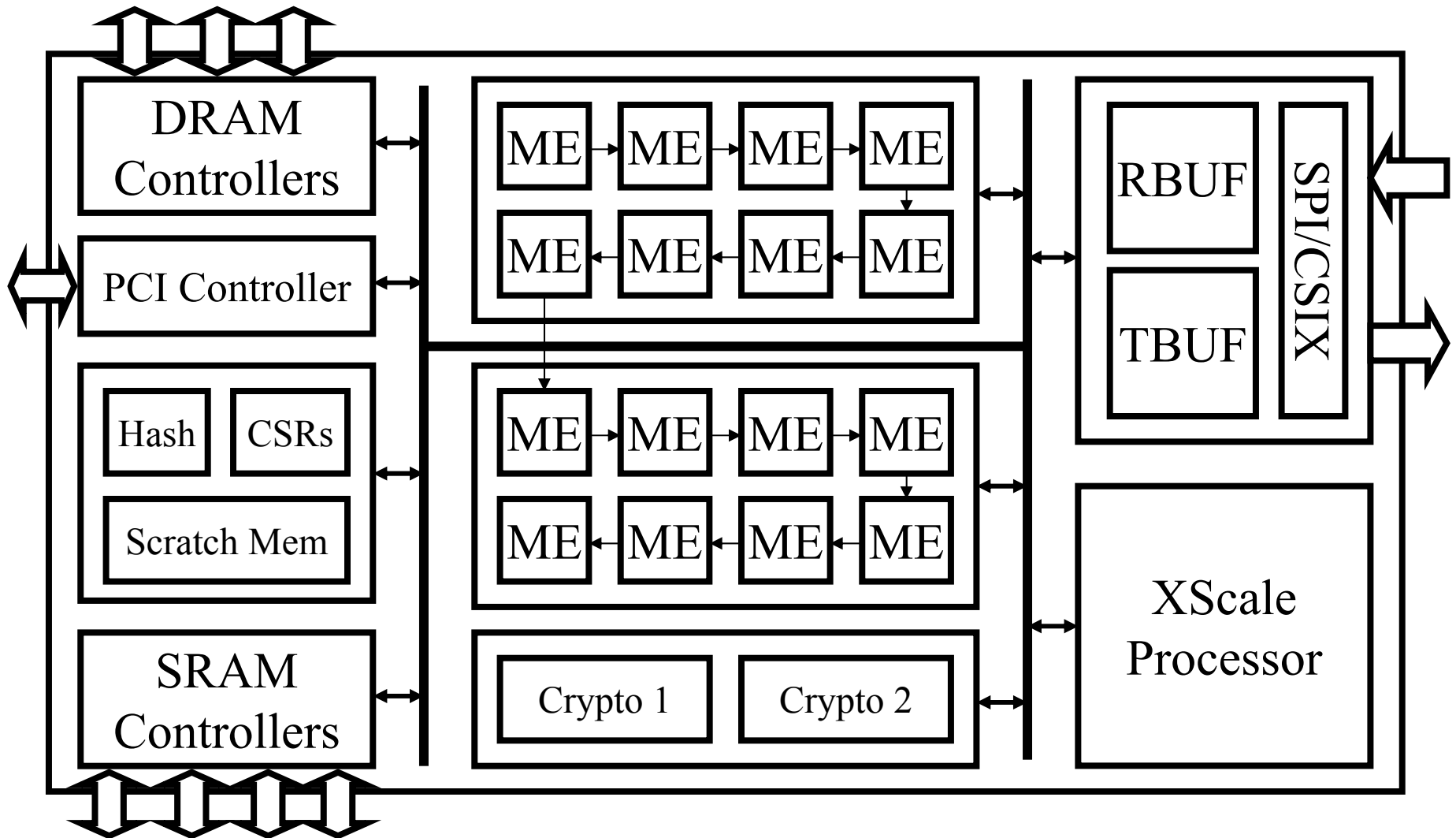

A Family of Chips

Cellphones!

More integration, higher volumes

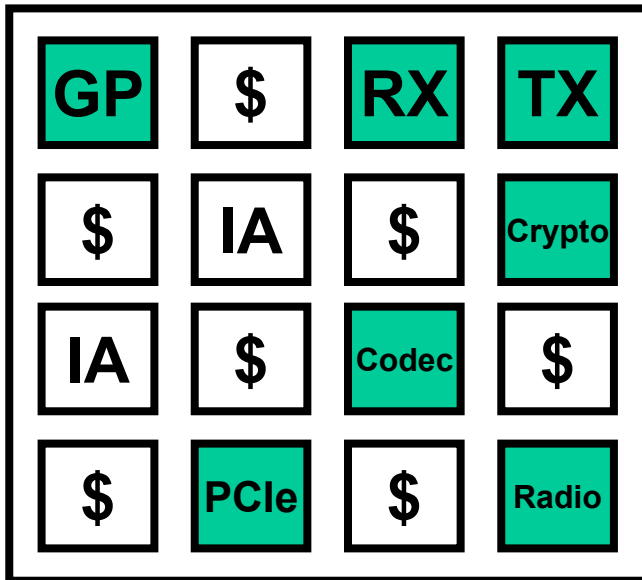

...

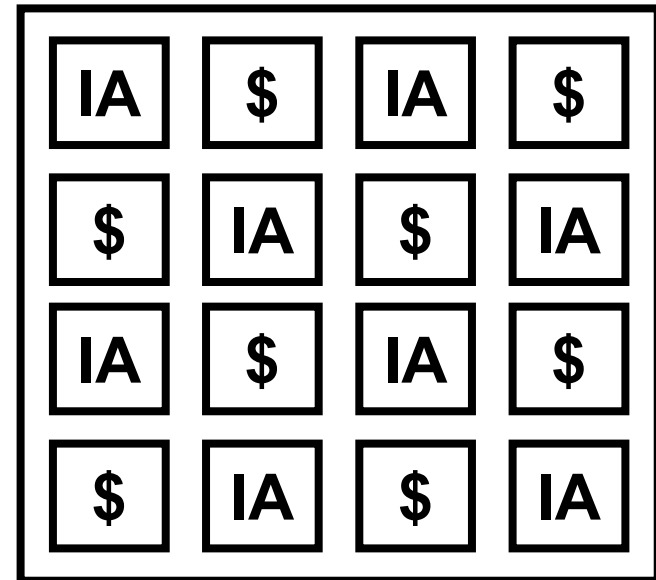

More G-P: cores, MIPS

Supercomputers!

Course Goals

1. Cultivate first-hand experience in using a multicore processor to solve problems
2. Place classic and recent research literature in parallel computer systems in appropriate modern context
3. Prepare students for cutting-edge research and development

Course Topics

(in approx. order of appearance)

- Multiprocessors, Multicomputers and the Intel IXP
- Methods for exploiting multicore parallelism
- Programming the IXP
 - I/O oriented tutorial
- Programming the IXP
 - Exploiting heterogeneous resources
- Projects
- Classic Machines and Projects
- Contemporary Machines and Projects

Course Structure

- 50% lecture and discussion
- 30% design meetings
- 20% presentations

Administrivia

- Office location: Bryan 522-D
- Office hours:
 - TBD
- Newsgroup:
 - `wu.cse.class.561`
 - Post commentaries here

The Next Several Weeks

- Introduction
 - Modern processors in the context of multiprocessors and multicomputers
 - Intro paper for Thursday
- IXP Architecture and Programming Model
- Receiving, Processing and Transmitting Packets with the IXP 2800
 - Tutorial
 - Programming experience
- Other problems

Potential Project Topics

- New this year: we will most likely use the Open Network Lab
- Past project topics
 - UDP multicast
 - Packet scheduling
 - High-speed encryption
 - Buffer management
 - Real-time packet scheduling
 - Virtual machine implementation
 - TCP flow classifier
 - Longest prefix match
 - Pattern matching
 - Bloom filter implementation
 - Packet classification algorithms
- Other ideas
 - Packet content search
 - Real-time flow identifier
 - Protocol implementation, e.g., SIP
 - ...

Commentaries

- Are brief essays that:
 - Demonstrate that you've read and understood the assigned reading
 - Ideally express a strong opinion, either critical or supportive, but an informed summary will suffice
- Should be approximately one page in length
- Need to be submitted to newsgroup before class

Assignment

- Thursday
 - HW #0, some parts completed ASAP
 - Order the textbook
 - **Commentary:** MPOC: A Chip Multiprocessor for Embedded Systems
- Tuesday
 - **Commentary:** The Next Generation of Intel IXP Network Processors