

Advanced Computer Systems Architecture

Chip-Multiprocessors: Applications and Architectures

CSE 561M

Prof. Patrick Crowley

Plan for Today

- Questions
- Today's discussion

Objective

- Ordered thread execution
- Discuss projects

Ordered Thread Execution

- Goal: make sure all threads on ME execute in strict order
- Rely on:
 - Non-preemptive thread scheduler/arbiter
 - Hardware signals
 - Safe access to shared data
- High-level procedure
 1. Signal next thread
 2. Do work
 3. Yield processor, wait for signal from previous thread, and all other I/O signals that were requested

Example: Multithreaded Increment

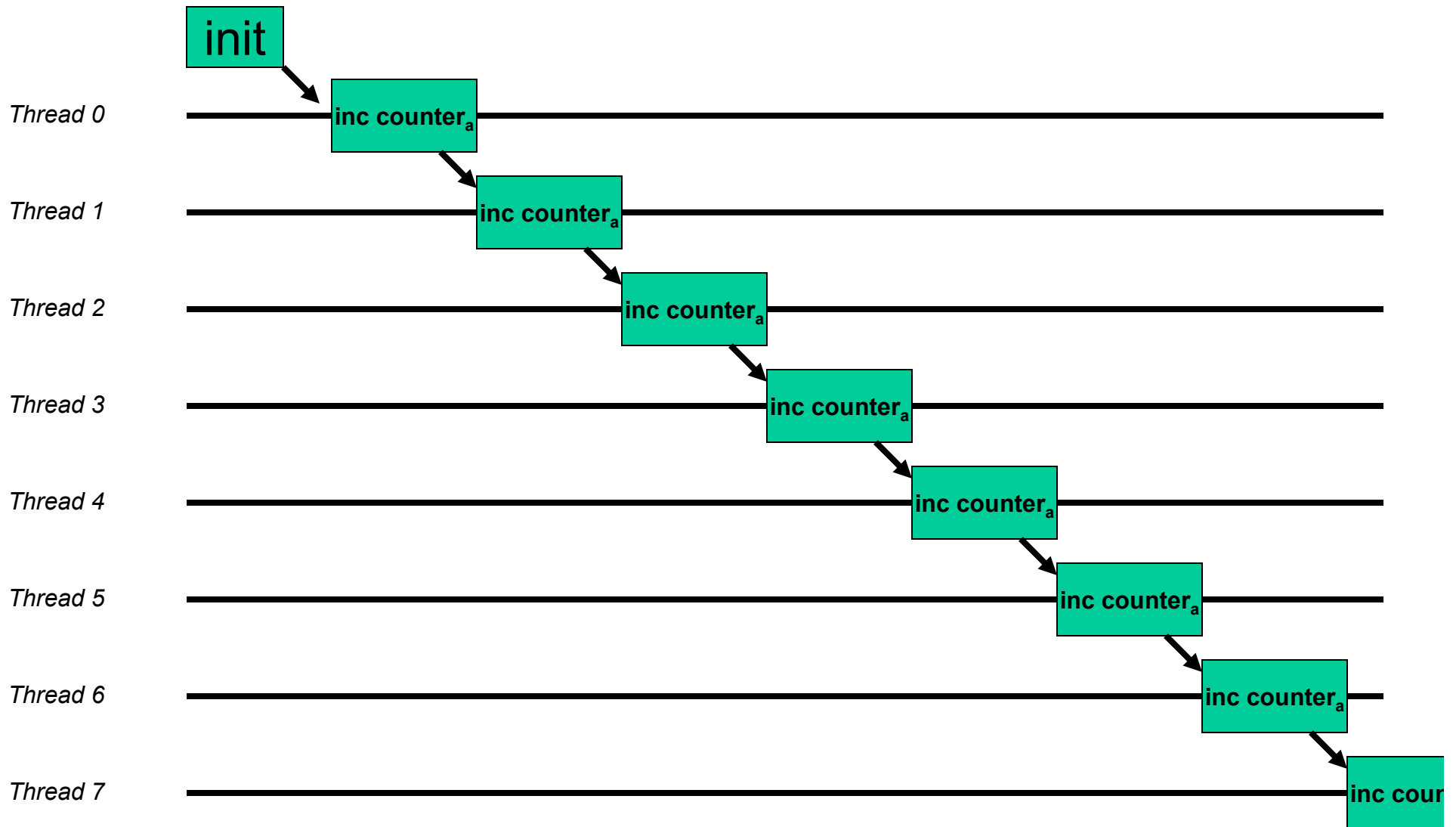

Declarations

```
//Declare Signal
.sig volatile SIG_1
.addr SIG_1 1
//Register used to hold val for SAME_ME_SIGNAL CSR
.reg signal_csr
//Allocate a counter in SRAM
.local_mem counter_a SRAM0 4
```

“always live”

Use HW sig 1

Signaling

```
//Macro for configuring the SAME_ME_SIGNAL CSR
#macro set_signal_csr[]
.begin
    immed[signal_csr, 0x80] //Set NEXT_CTX bit to 1
    //Shift the dest signal number by the reqd 3 bits
    alu_shf[signal_csr, signal_csr, OR, &SIG_1, <<3]
.end
#endm

//Macro for signalling the next ctx
#macro signal_next_ctx[]
.begin
    local_csr_wr[SAME_ME_SIGNAL, signal_csr]
.end
#endm
```

Configuring the ME Local CSR

5.2.14 SAME_ME_SIGNAL

The SAME_ME_SIGNAL CSR allows a thread to signal another Context in the same Microengine. The data is used to select which Context and signal number is set.

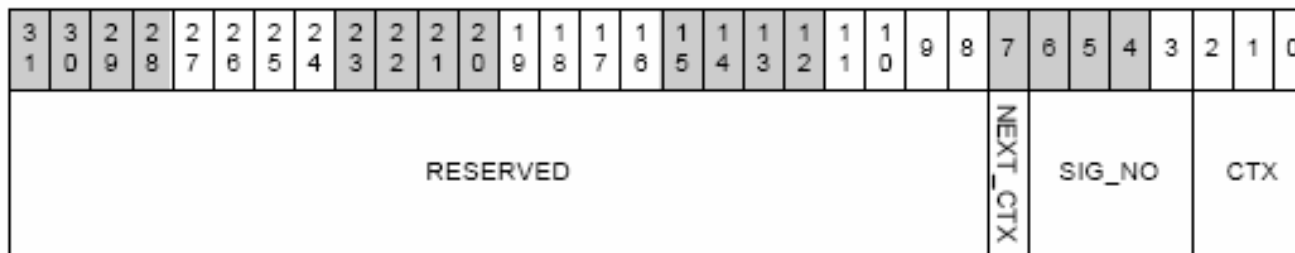

Bits	Field	Description	RW	Reset
[31:8]	Reserved		W	0
[7]	NEXT_CTX	Controls whether or not the Context field of this register is used in selecting the Context that is signaled in the Microengine. 1—Signal the Context that is one greater (modulo the number of Active Contexts in CTX_ENABLE[IN_USE_CONTEXTS]) as the one that does the write to this register. This is useful if running common code on multiple Contexts that need to signal the next sequential Context. 0—Use the Context field of this register to select the Context in the Microengine.	W	0
[6:3]	SIG_NO	Signal to set in the Microengine.	W	0
[2:0]	CTX	Context to signal in the Microengine. This field is only used if NEXT_CONTEXT is not asserted.	W	0

Counter Initialization

```
//Initialize the counter
#macro init[]
.begin
    .reg $init_counter, counter_addr
    .sig sram_done
    immed[$init_counter, 0]
    immed[counter_addr, counter_a]
    sram[write, $init_counter, counter_addr, 0, 1], ctx_swap[sram_done]
.end
#endm
```

Program Code

```
// This is the main part of the program
.begin
    .reg counter_addr
    immed[counter_addr, counter_a]
    set_signal_csr[]
    //Only ctx 0 will call init
    .if(ctx() == 0)
        init[]
    .else
        ctx_arb[SIG_1]
    .endif
    .while(1)
        signal_next_ctx[]
        sram[incr, --, counter_addr, 0]
        ctx_arb[SIG_1]
    .endw
    ctx_arb[kill]
.end
```

Sample Project

- Multithreaded increment
- Multithreaded sum

Project Logistics

- Groups of one or two
- We will plan to use NP routers in ONL
- Weekly Milestones
 - Milestone report due each week
 - Submit proposal Feb 26
 - Final presentation Apr 15

Project Milestones

M0	Feb 26	Project Proposal
M1	Mar 4	Design
M2	Mar 18	Implementation 1
M3	Mar 25	Implementation 2
M4	Apr 1	Implementation 3
M5	Apr 8	Wrap-up, Prepare reports
M6	Apr 15	Presentations

ONL NP Router

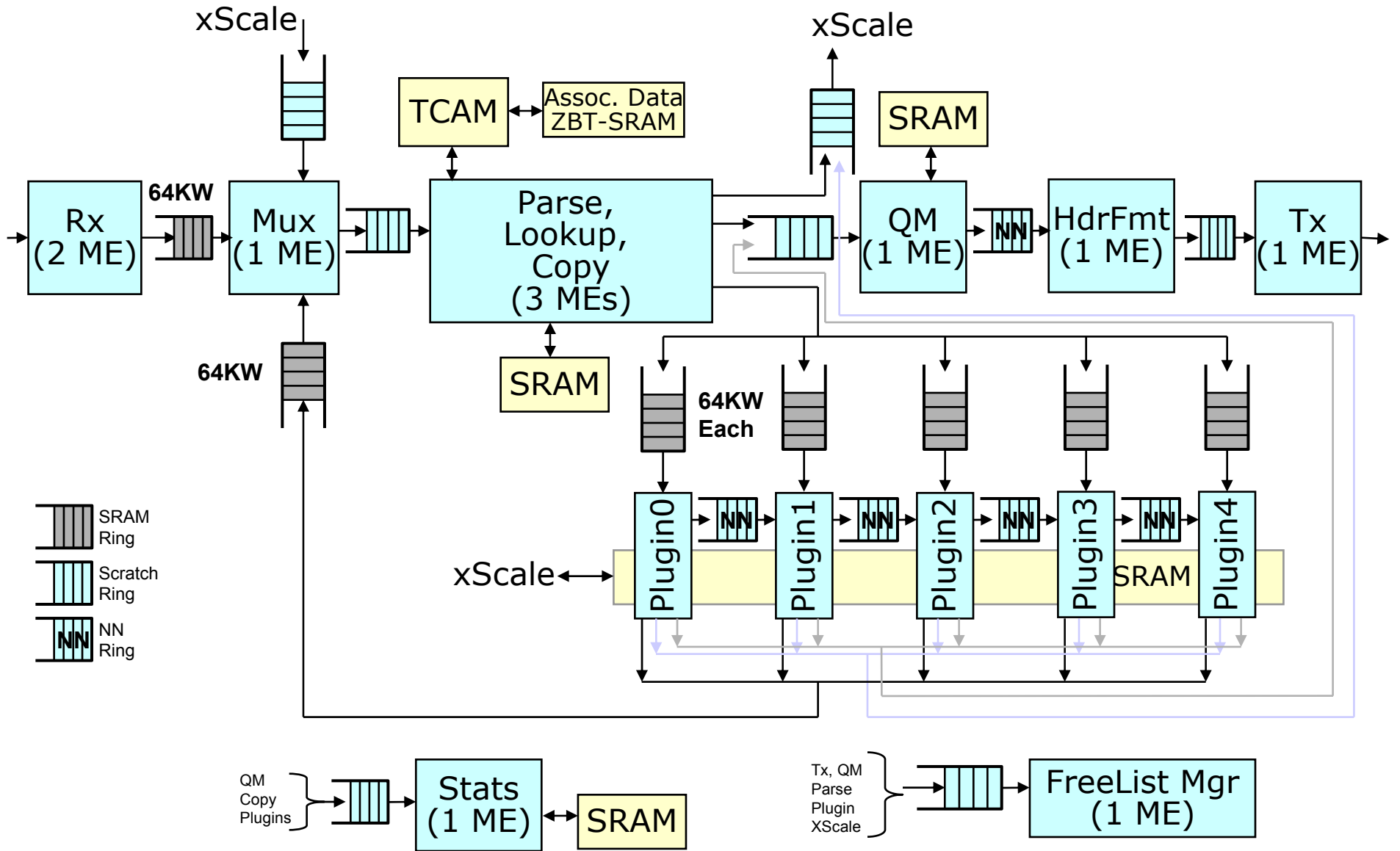

Potential Project Topics

- Networking
 - Traffic and flow monitor
 - Queue management
 - Protocol implementation
 - SIP, RSVP, Bittorrent
 - IP multicast
 - Packet content search or transformation
 - Extract info from image, video data
- Or other topics of interest to you
 - If you have a special interest, email me *ASAP*

Assignment

- Tuesday
 - J&K: Read Ch. 9
- Thursday
 - J&K: Skim Ch. 10, Ch. 11

Assignment

- Wednesday, Feb 22
 - J&K: Read Ch. 9
- Monday, Feb 27
 - Project Proposal :
 - Determine group members
 - Propose project idea
 - Use sentences and paragraphs to describe the project
 - 6 week project
 - Break project into milestones (see project logistics slide)
 - Use sentences and paragraphs
 - Demonstrate some understanding of the problem
 - Submit document to newsgroup, and bring hardcopy to class