

# Advanced Computer Systems Architecture

## Chip-Multiprocessors: Applications and Architectures

CSE 561M

Prof. Patrick Crowley

# Plan for Today

- Questions
- Today's discussion

# Objective

- Introduce ONL NP router simulation project
  - How to install and setup the project
  - How to simulate the default configuration
  - How to insert your own plugin code
- Review project logistics and topics

# Installation and Setup

- Project is a mix of source and binary, so the project setup process is a bit different
- Instructions are found in README file
- Basic Steps
  - Make sure cygwin is installed
  - Unpack ONL\_Router\_SIM.tar.gz; this creates folder ONL\_Router\_SIM in curr directory
  - Open project file
  - Build (DO NOT Re-build), expect an error
  - Run touchup.sh script
  - Build (DO NOT Re-build)

# ONL NP Router Organization

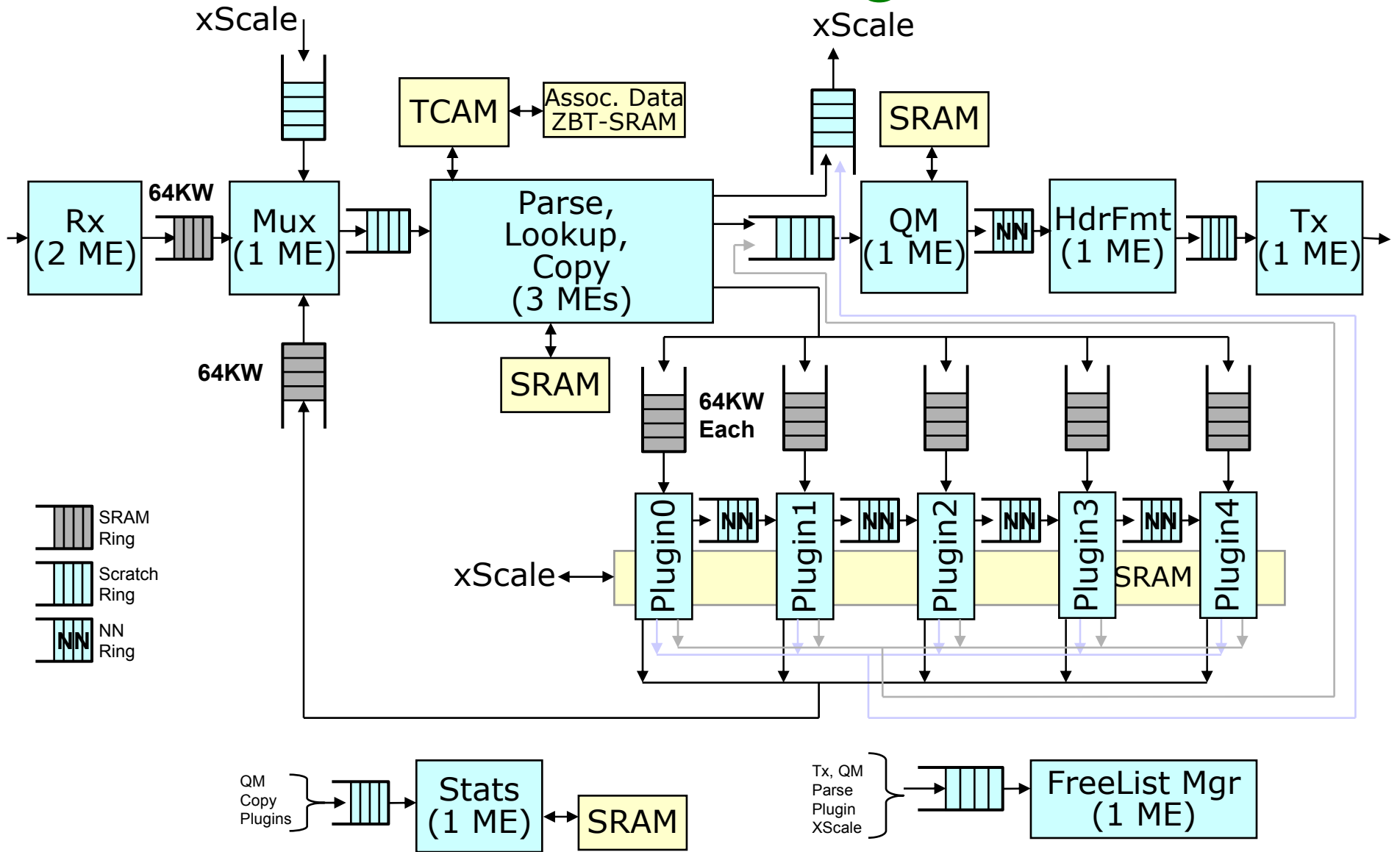

# Where does the code reside?

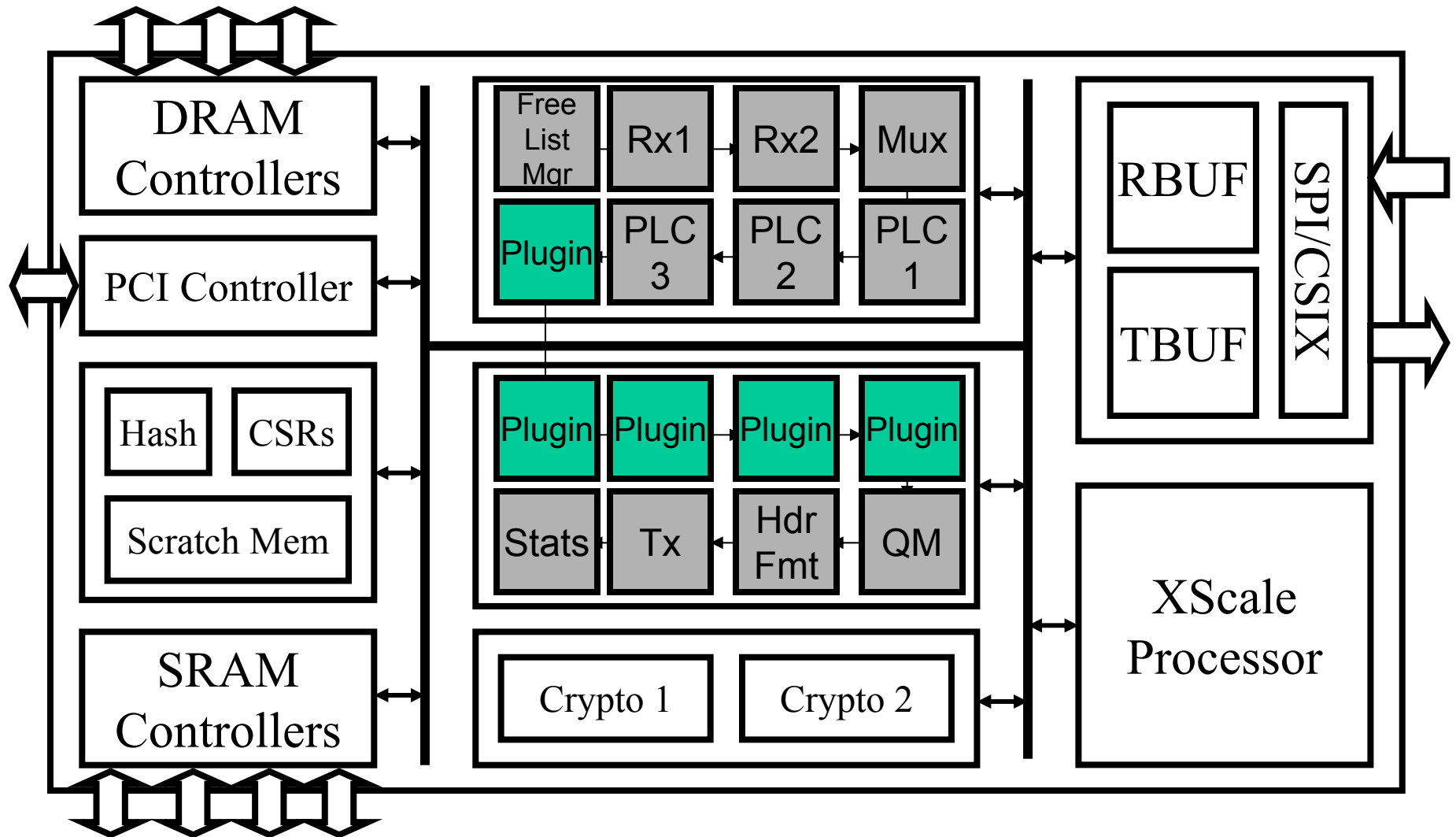

# Simulate the Default Configuration

- The project simulates “out of the box”
- Traffic
  - Sample traffic is included
  - You cannot control the packet classification in simulation, since there is no TCAM
  - By default, packets are sent to plugins based on the lower 3 bits of their Dst IP addr
    - Dest addr 0->4 go to plugins 0->4
    - Dest addr 5-7 go to output ports 0-2 (via the QM, not to any plugin)
  - There are 8 UDP/IP/Ethernet flows created, each to a different Ethernet port, each with a different final 3 bits
  - You can always change the flows to direct traffic

# Inserting Your Own Code

- For now, define the Plugin API functions
  - `void handle_pkt_user()`
  - `void handle_msg_user()`
  - `void callback_user()`
  - `void plugin_init_user()`
- Recall for each Plugin ME:
  - Contexts 0-5: `handle_pkt_user()`
  - Contexts 6: `handle_msg_user()()`
  - Contexts 7: `callback_user()`

# Example Code & Simulation

- See workbench

# Beware of Premature Optimization

- Time needed for forward 30 packets
  - Null Plugin: 35033
  - Count via Read, Modify, Write : 36069
  - Count via Increment : 35559
- Try not optimize until you have a reason

# Project Proposal

## Milestone 0 - Project Proposal

- Determine group members and name
- Propose project idea
  - Use sentences and paragraphs to describe and motivate your idea
  - Discuss the challenges and implementation questions you need to consider to finalize your design
- Break project into 6 milestones (see project logistics slide)
  - Use sentences and paragraphs to describe each milestone goal
  - Demonstrate a non-superficial understanding of the problem
- Try to limit your proposal to 2 or 3 pages
- Submit document to newsgroup, and bring hardcopy to class

# Project Logistics

- Groups of one or two
- We will plan to use NP routers in ONL
- Weekly Milestones
  - Milestone report due each week
  - Submit proposal Feb 26
  - Final presentation Apr 15

## Project Milestones

M0	Feb 26	Project Proposal
M1	Mar 4	Design
M2	Mar 18	Implementation 1
M3	Mar 25	Implementation 2
M4	Apr 1	Implementation 3
M5	Apr 8	Wrap-up, Prepare <b>reports</b>
M6	Apr 15	<b>Presentations</b>

# Assignment

- Tuesday
  - **Milestone 0 - Project Proposal Due**
    - Determine group members and name
    - Propose project idea
      - Use sentences and paragraphs to describe and motivate your idea
      - Discuss the challenges and implementation questions you need to consider to finalize your design
    - Break project into 6 milestones (see project logistics slide)
      - Use sentences and paragraphs to describe each milestone goal
      - Demonstrate a non-superficial understanding of the problem
    - Try to limit your proposal to 2 or 3 pages
    - Submit document to newsgroup, and bring hardcopy to class
- Thursday
  - J&K: Ch. 12